

RECOMMENDED MAINTENANCE SCHEDULE FOR DETENTION BASIN 96

CLEARING OF SEDIMENT FROM SEDIMENTATION BASINS: EVERY 3 MONTHS AS NEEDED DURING FIRST YEAR AFTER FINAL SITE STABILIZATION. ANNUAL AS NEEDED THEREAFTER.

CLEARING OF SEDIMENT FROM FULL POND AREA: EVERY 10 YEARS AS NEEDED.

OUTLET STRUCTURE: WEEKLY AS NEEDED.

PROPOSED DETENTION BASIN 96

	Q10	Q100
IN	781 cfs	1939 cfs
OUT	116 cfs	696 cfs

PROPOSED DETENTION BASIN 96

100-YR WSEL = 6646.64
10-YR WSEL = 6644.58
VOLUME = 138.4 AC-FT

- NOTES:**
- SEE CITY OF COLORADO SPRINGS STANDARD DRAWINGS D-33 THROUGH D-36 FOR ALL CONCRETE HEADWALL, WINGWALL, AND FOOTING DETAILS.
 - ALL TOE WALLS SHALL BE A DEPTH OF 5' UNLESS SPECIFIED ON PLANS DUE TO ADDITIONAL SCOUR DEPTH.
 - ALL HEADWALLS SHALL BE 1' ABOVE TOP OF CULVERT
 - SEE CHANNEL PLAN AND PROFILES FOR WATER SURFACE ELEVATION INFORMATION, GRADING, AND RIPRAP DETAILS.
 - ALL SIDE SLOPES ARE PER THE TYPICAL SECTIONS, 4:1 UNLESS NOTED OTHERWISE.
 - REFER TO BLR FILING 1, PHASE 1 - CONSTRUCTION PLANS FOR DETAILS REGARDING ROADS, ROADWAY GRADING AND STORM SEWER.

REVIEW:

Street Design: _____ Date _____

Traffic Engineering: _____ Date _____

Curb & Gutter Review: _____ Date _____

Final Design Review: _____ Date _____

Drainage Design: _____ Date _____

Drainage Basin Filled in Accordance with Section 15-3-906 of Colorado Springs 1980, As Amended

48 HOURS BEFORE YOU DIG CALL UTILITY LOCATORS
1-800-922-1987
 City of Colorado Springs Dept. of Utilities Gas, Electric, Water and Wastewater
 The locations of existing underground utilities are shown in an approximate way only. The contractor shall determine the exact location of all existing utilities before commencing work. The contractor shall be fully responsible for any and all damages which might be caused by his failure to exactly locate and preserve any and all underground utilities.

***B**
 BANNING LEWIS RANCH
 "The Promise of Colorado"

TCB
 Engineers-Planners-Project Managers
 PH: 303-296-7117 FAX: 303-296-1124

DRAFT

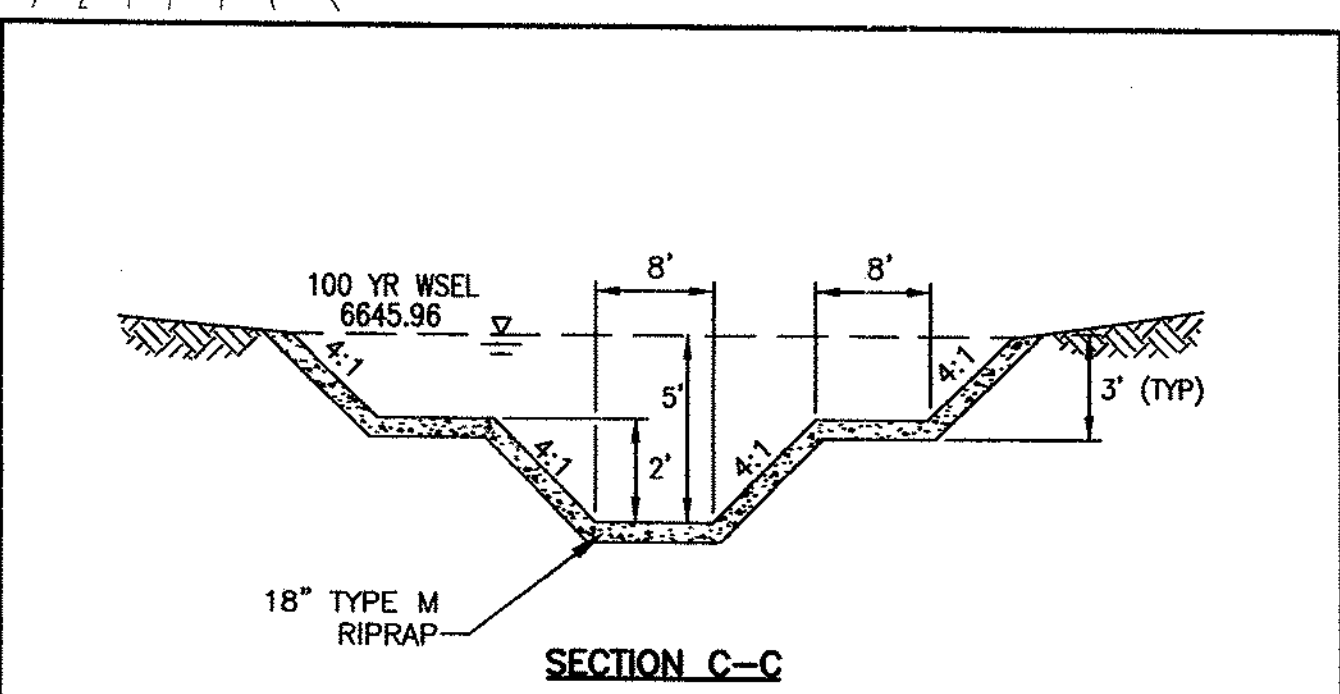
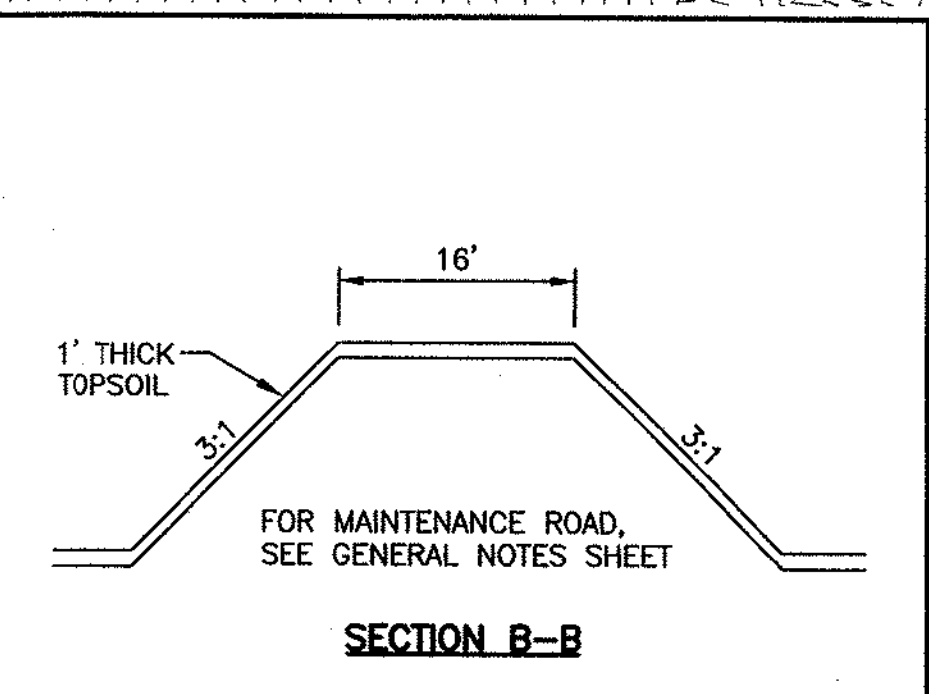
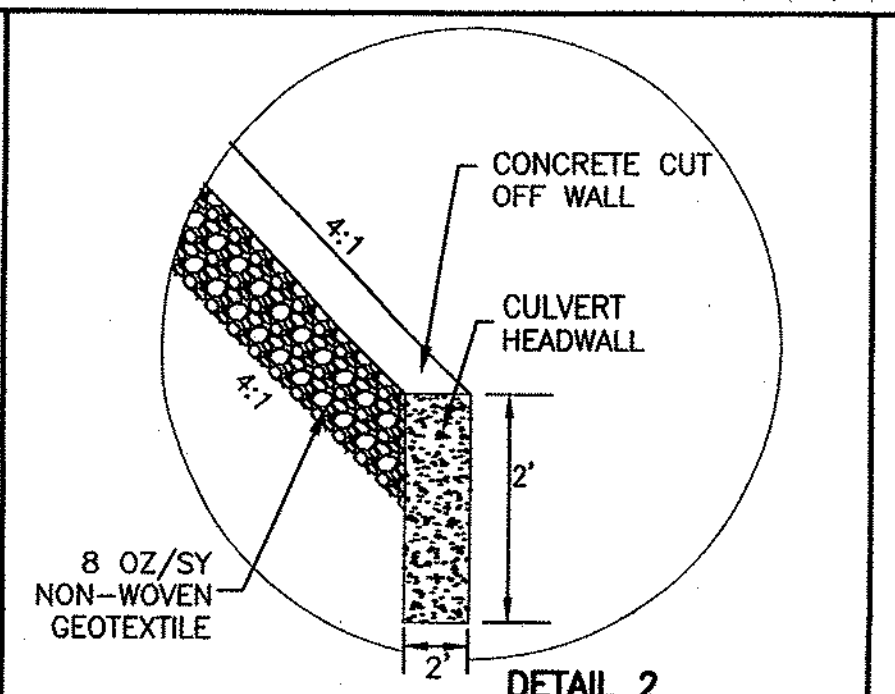
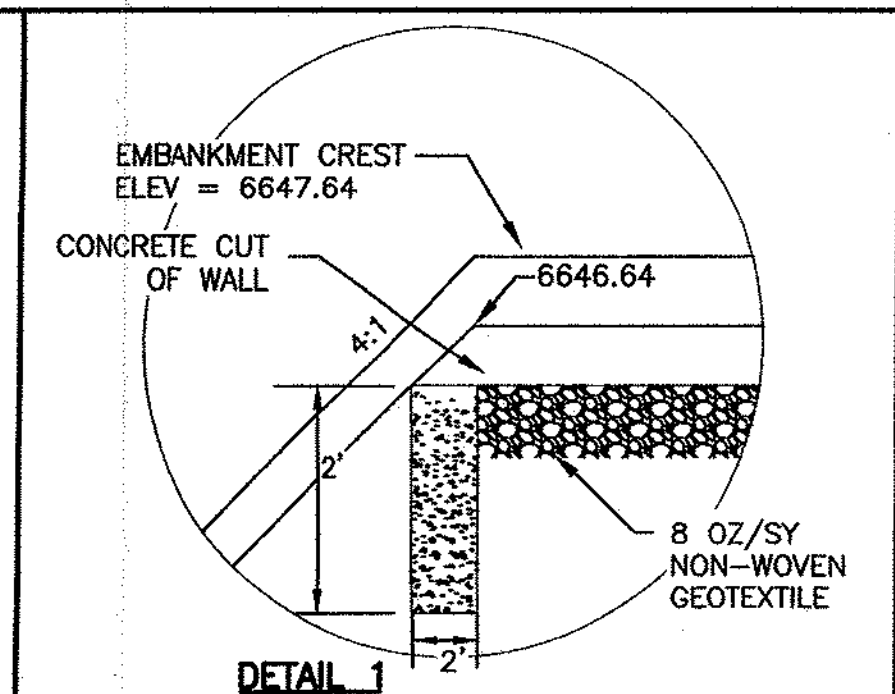
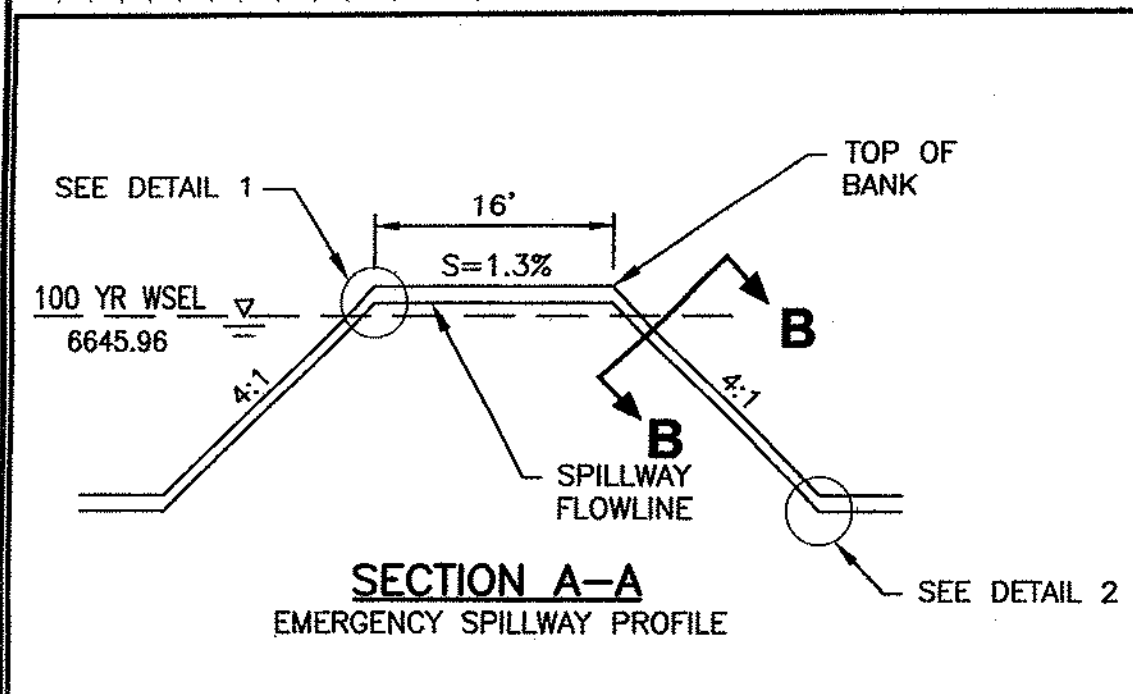

DETENTION BASIN 96

2	3/5/04	CITY COMMENTS - 2ND REVIEW	
1	1/20/03	CITY COMMENTS - 1ST REVIEW	
NO.	DATE	REVISION	BY
Unit:	LDS	Scale: Horz. 100'	Date: JUNE 17, 2003
Designed:	CLK	Vert. N/A	Job No. 251395
Drawn:	BJM	Approved:	Sheet 15 of 35

M:\BLR\251395\DWG\251395-03\PHASE 1\PLAN\DWG\251395-03-01.dwg, SHEET: MAIN/BLR, 07/20/04 08:20:30 AM, Memory: 11, TCB